

MODEL "ELX-UVi-BBC-CL"

HIGH EFFICIENCY EXTRACTOR VENTILATOR

GENERAL SPECIFICATIONS AND DESCRIPTION

Furnish Gaylord Ventilator Model "ELX-UVi-BBC-CL-_____" as shown on plans and in accordance with the following specifications:

HIGH EFFICIENCY EXTRACTION: Each ventilator shall contain "XGS" High Efficiency Extractors utilizing the "capture and drain" principle. Extractor efficiencies shall be determined using ASTM F2519-2005 testing procedures as accepted by ASHRAE TC 5.10 and ASHRAE Standard 154-2011 - 4.7.2. The High Efficiency Extractors shall not exceed 55 db, on typical cooking lines, as measured at the chef's ear so fatigue is minimized and productivity is optimized.

CAPTURE AND CONTAINMENT: Each ventilator shall achieve capture and containment using the lowest possible airflow rates through "passive" versus "active" design features, thus eliminating the wiring or adjustment of internal motors, plenums or jets. The ventilator shall include an integrated capture wall to achieve its airflow rates. The lowest possible airflow rates shall be tested to ASTM 1704-09 by the Food Service Technology Center and published on their website for easy confirmation.

<http://www.fshnick.com/publications/appliancereports/hoods/>

ULTRAVIOLET IRRADIANTS: The ventilator shall include ultraviolet lamps mounted in modules located in the plenum section. There shall be one or more UVi modules, as dictated by the ventilator length, and each module shall be on a slide track for easy removal. Access to the UVi modules shall be through tooled removable UV module doors. Two pressure switches shall be provided to monitor the airflow and prevent operation of the UVi lamps if the access doors are open, or if any "XGS" Extractor is removed, or if the airflow is inadequate. Mounted on the face of the plenum of each ventilator section shall be status lights to monitor "UVi System On," "UVi Lamp Failure" and "UVi Safety Interlock Activated." The Gaylord Command Center shall display text that duplicates the ventilator mounted status lights.

CONSTRUCTION: The ventilator shall be of all stainless steel construction, not less than 18 gauge, type 300 series. All exposed surfaces shall be a number 4 finish. The use of aluminized steel or galvanized steel is not acceptable. The ventilator shall include a "V" bank arrangement of "XGS" Super High Efficiency Filtration Extractors. The ventilator shall include a static pressure port in each section to be used in balancing exhaust air volumes. Continuous front and rear mounting brackets shall be provided to facilitate mounting to the wall and hanging from the overhead building structure. Each duct collar shall include as standard a Gaylord Balancing Damper (GBD) with opposed blades that adjust manually through access from within the canopy. Ventilators built in end-to-end multiple sections shall have as standard "Continuous Capture" from one end to the other to ease cleaning and improve capture and containment.

LIGHT FIXTURES: The ventilator shall be equipped with:

- | | |
|--|-------------------|
| <input type="checkbox"/> Recessed LED | 6 Watts/Ft. Min. |
| <input type="checkbox"/> Recessed fluorescent | 12 Watts/Ft. Min. |
| <input type="checkbox"/> 100 watt surface mounted incandescent | 24 Watts/Ft. Min. |
| <input type="checkbox"/> 150 watt recessed incandescent | 36 Watts/Ft. Min. |

Light fixtures shall be factory pre-wired to a single connection point. Ventilators built in multiple sections shall be furnished with coiled flex conduit for interconnecting sections.

ACCEPTANCE & APPROVALS: Each ventilator shall include an integral "Autostart" controller and sensors to meet current IMC standards (optional outside North America). Each ventilator shall be Listed to UL Standard 710, ETL Sanitation, comply with all requirements of NFPA-96, IMC, UMC, BOCA, and SBCCI mechanical codes and be capture tested to ASTM 1704-09 with High Efficiency Extractors tested to ASTM 2519-2005.

ITEM NO. _____

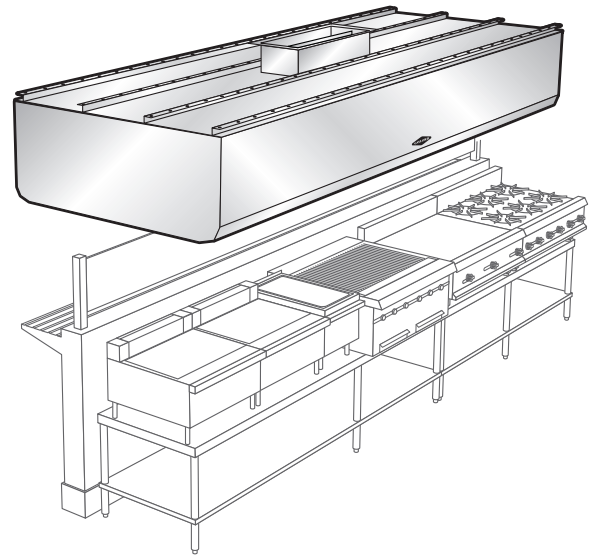

APPLICATION

Used for cafeteria lines or single island arrangements for use over all types of equipment; ovens, broilers, griddles, fryers, ranges, steam equipment, etc.

DESIGN FEATURES

- Internal Canopy Radius
- Enhanced "XGS" Extractor Angle and Slot Spacing
- Faceted "Super Capture"™ Lip

OPTIONAL EQUIPMENT

1. Decorative Facings and Trim
2. Demand Control Ventilation
3. Fire Extinguishing Systems
4. Pollution Control Systems
5. Utility Distribution Systems
6. "XGS" Spark Arrestor Extractors



Intertek



Intertek

GAYLORD INDUSTRIES

10900 SW AVERY ST • TUALATIN, OREGON 97062 U.S.A.
PHONE: 800.547.9696 • FAX: 503.692.6048 • email: info@gaylordusa.com

www.gaylordusa.com

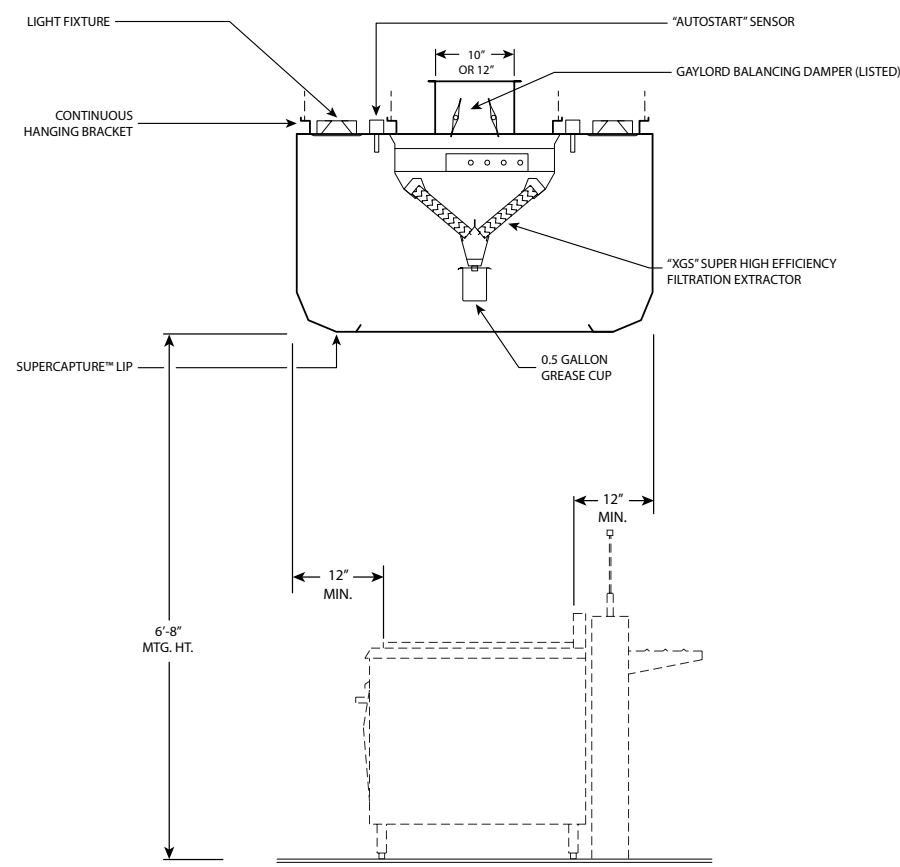
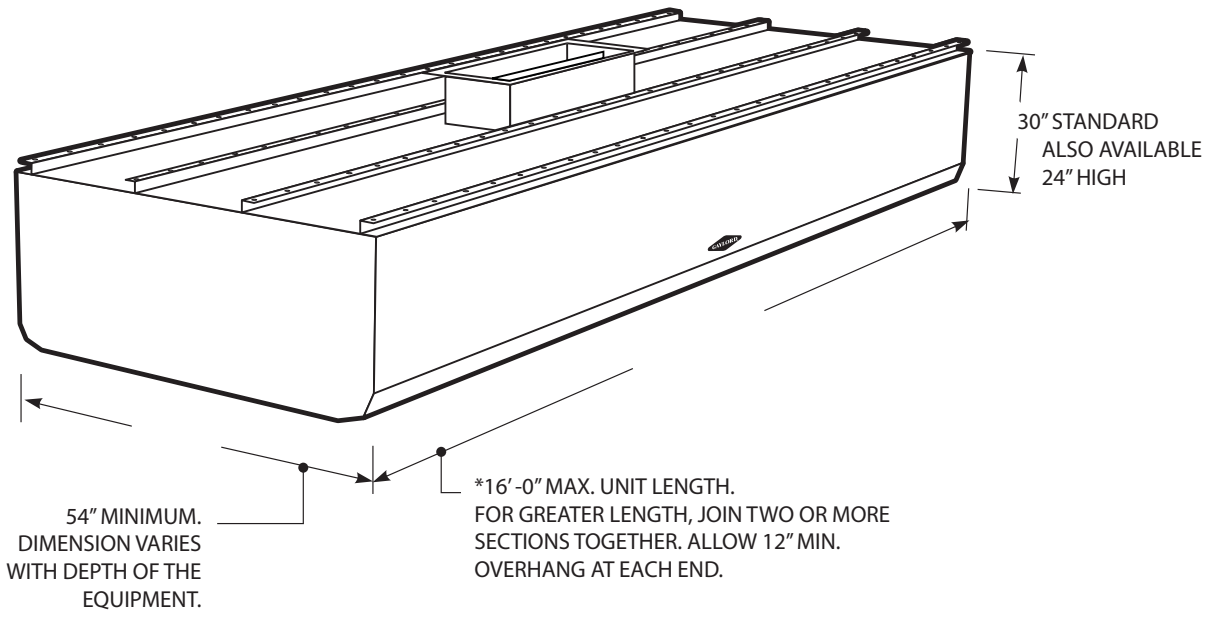

ENGINEERING DATA

Mechanical Requirements

The amount of exhaust volume required is dependent upon the type of cooking equipment and the type and volume of cooking. Contact factory for exhaust volumes, duct sizes, and static pressures.

Electrical

☐ Provide 208-250VAC, 50/60 Hz, Single Phase, 20 amp service for every 2 ventilator sections to power UVI lamps. Ventilator lights to be on separate circuit, 120 volt 50/60Hz standard, 220/240 volt optional.

Ventilator Lengths

Maximum unit length 16'-0". For greater lengths, join two or more sections together. Check to ensure that there is adequate access into building and kitchen area.

* **Note:** Ventilators manufactured outside North America; maximum unit length 10'-0".

Hanging Weight

Ventilator Width	54"	60"	66"
Wt. / Lineal Ft.	Lbs. 125	130	135

The manufacturer reserves the right to modify the materials and specifications resulting from a continuing program of product improvement or the availability of new materials